



# Radio Info

**Sprinter Engineering & Compliance**

01-01-2010





## Disclaimer

The specifications, descriptions, information, and recommendations contained in this bulletin are believed to be accurate as of Jan 1<sup>st</sup>, 2009.

Sprinter Engineering & Compliance reserves the right to modify or append this document without prior notification.

This bulletin is not intended as a work instruction, but as an aid for Body Builders to provide technical information necessary to retrofit or modify Mercedes-Benz Sprinters & Freightliner Sprinters (906).

Prior to making any modification to or installing any equipment in or on a Mercedes-Benz Sprinter & Freightliner Sprinter, please check with the Sprinter Engineering & Compliance for additional and updated information, and read the Sprinter Body Builder Information Book Model Series 906.

[www.sprinter-engineeringcompliance.com](http://www.sprinter-engineeringcompliance.com)

### Sprinter Engineering & Compliance Support Team Contacts:

Walther F Bloch  
Manager  
843-695-5053

[walther.bloch@daimler.com](mailto:walther.bloch@daimler.com)

Andreas Brockmann  
Support Engineer  
843-695-5052

[andreas.j.brockmann@daimler.com](mailto:andreas.j.brockmann@daimler.com)

Jochen Hornikel  
Test Engineer  
843-695-5064

[jochen.hornikel@daimler.com](mailto:jochen.hornikel@daimler.com)



## Sound 5 (standard equipment)

**Sound 5** stereo CD radio.

### **Radio features:**

VHF, MW, LW and SW with ten station presets per FM band and five per AM band, rotary volume control, speed-dependent volume adjustment, four-level volume control for traffic news, automatic station scan, SCAN function (plays approx. 8 seconds of each receivable station), manual station tuning, automatic station store (Autostore) stores strongest stations, station identity displayed in radio display (Radio Data System).

### **CD player features:**

Single-disc audio CD player with soft eject, automatic reload after approx. 10 seconds, next track/previous track function, random order play, SCAN function (plays the first eight seconds - approx. - of each track), track repeat, track time elapsed/CD time elapsed display.

### **General features:**

4x20-watt output, bass and treble separately adjustable, stereo balance control, fader, 5 cockpit speakers (2 mid-range woofers, 2 tweeters, 1 centre speaker),



Subject to change



## Sound 20 (Option EJ3) Radio AM/FM, 6 disc CD, w/ Bluetooth

### Basic functions:

- 5-inch TFT color display
- 6 disc CD changer
- Telephone keypad
- AUX-IN connection on the rear of the unit
- Bluetooth hands-free system
- The unit can be operated via the multifunction steering wheel (Code CL4).

### Output and sound:

- 4 x 25 Watts output
- includes 5 front speakers and Passenger Van includes 8 additional rear speakers
- Speed-sensitive volume control, gradual increases volume starting at 12 mph

### Radio:

- Wavebands FM, AM
- 10 station memory positions per waveband
- SCAN function (each station is tuned in for approx. 8 seconds)
- Manual station selection

### CD-player

- 6 disc CD-player with Soft Eject
- Supports MP3 and WMA audio files
- SCAN function (all tracks are played for approx. 8 seconds)
- Display of current track playing time

### Telephone support

- Bluetooth hands-free system as standard (compatible with many Bluetooth mobile phones)
- can import the mobile phone book via Bluetooth (compatible with many Bluetooth mobile phones)





## 5 FRONT SPEAKERS (EL8)

Two-way loudspeaker system plus one center speaker. One mid-range woofer is fitted in the driver's door and one in the co-driver's door. The center speaker and the tweeters are integrated in the instrument panel.

(standard on cargo vans and chassis-cab with radio and radio prep CODE ER0)

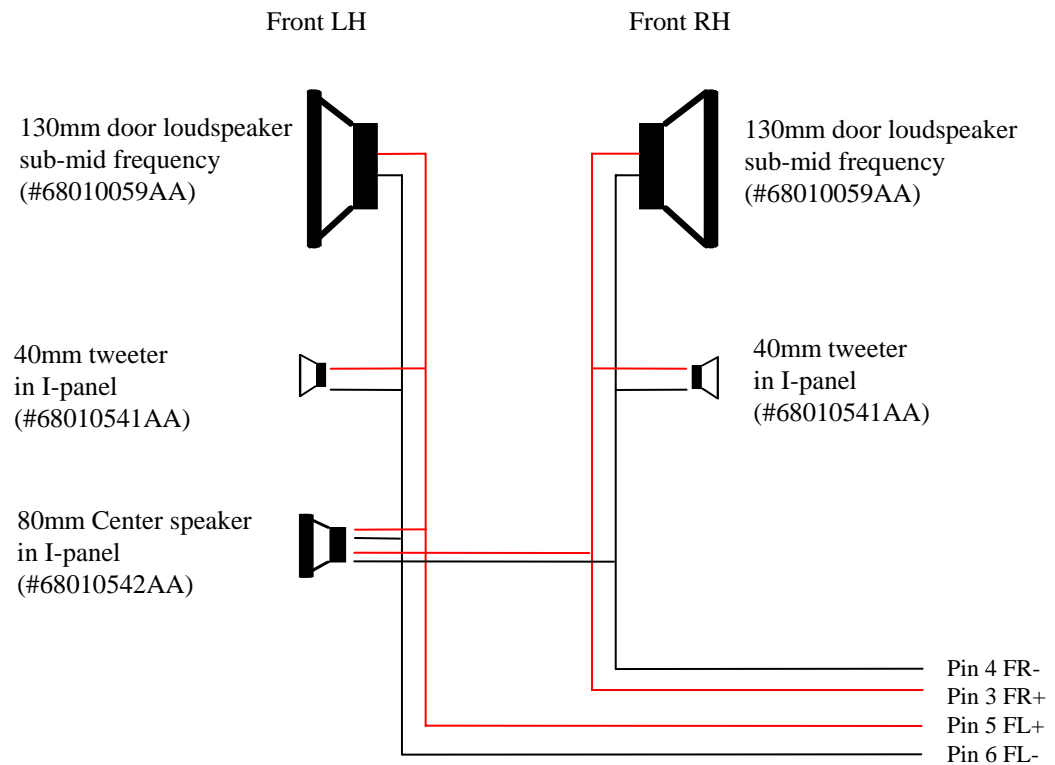

See page 8



## 5 FRONT, 8 REAR SPEAKERS (EL9)

Two-way loudspeaker system: the 5 front speakers are extended with a further four tweeters and four mid-range woofers fitted in the sidewall/sliding door and in the left and right-hand rear side paneling in the passenger compartment.

(standard on passenger van with radio and passenger van radio prep CODE ER0)



Front LH

Front RH

See wiring diagram Page 5

40mm tweeter in I-panel (#68010541AA)

130mm door/Sidewall loudspeaker sub-mid frequency (#68013427AA)

40mm tweeter in I-panel (#68010541AA)

130mm door/Sidewall loudspeaker sub-mid frequency (#68013427AA)

Pin 4 FR-  
Pin 3 FR+  
Pin 5 FL+  
Pin 6 FL-

Pin 8 RL -  
Pin 7 RL +  
Pin 1 RR+  
Pin 2 RR-

See page 8

40mm tweeter in I-panel (#68010541AA)

130mm door/Sidewall loudspeaker sub-mid frequency (#68013427AA)

40mm tweeter in I-panel (#68010541AA)

130mm door/Sidewall loudspeaker sub-mid frequency (#68013427AA)

## 5 FRONT, 8 REAR SPEAKERS (EL9) cont.

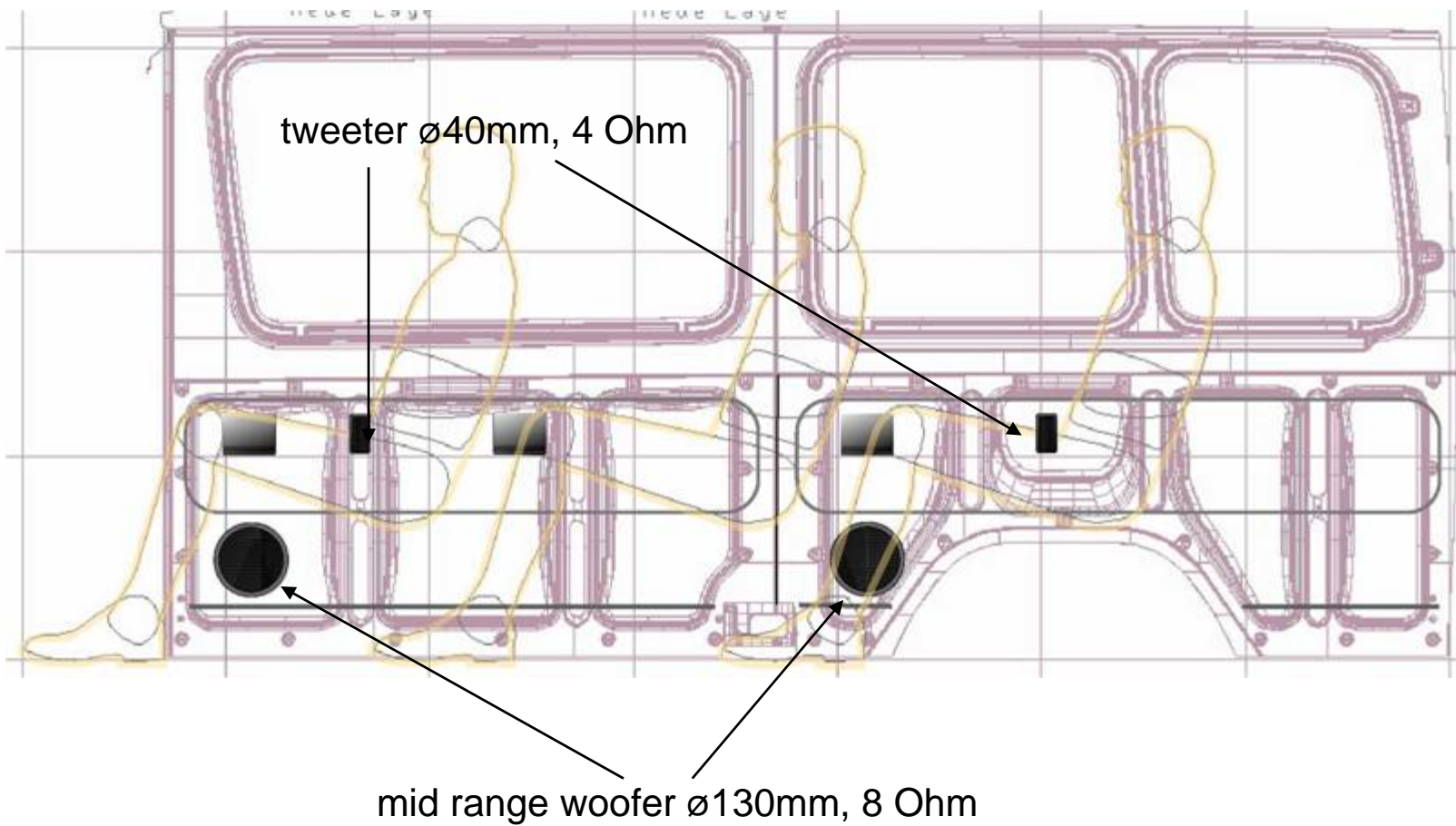



## CODE ER0 Preparation for Radio Retrofit

Pre-installation for radio

Pre-wiring (12 V) for retrofitting a (commercially available) radio, plus short-range interference suppression and a flexible stub antenna on roof. Chassis Cab and Cargo Vans have 5 front loudspeakers (EL8), Passenger Vans come with 5 front and 8 rear loudspeakers (EL9).



Note:

The pre-installation for radio does not support CAN/MOST technology. Additional wiring must be retrofitted in order to retrofit a factory supplied radio. Without this wiring, functions such as recognition of the key position (radio continues to operate after the ignition key has been removed etc.) as well as control of the radio via the multifunction steering wheel and display of radio information in the instrument cluster are not supported.

As the factory-supplied radios are larger than the DIN slot, the radio opening must also be replaced when retrofitting a factory-supplied radio.



## CODE ER0 pin layout radio connector

- A1 n.c
- A2 n.c.
- A3 n.c.
- A4 KI30 (+12V battery direct power)
- A5 switch `Antenna`
- A6 terminal 58D (display illumination)
- A7 terminal 15R (ACC accessory power on)
- A8 KI31 (Ground)
  
- B1 LS rear right +
- B2 LS rear right -
- B3 LS front right +
- B4 LS front right -
- B5 LS front left +
- B6 LS front left -
- B7 LS rear left +
- B8 LS rear left -

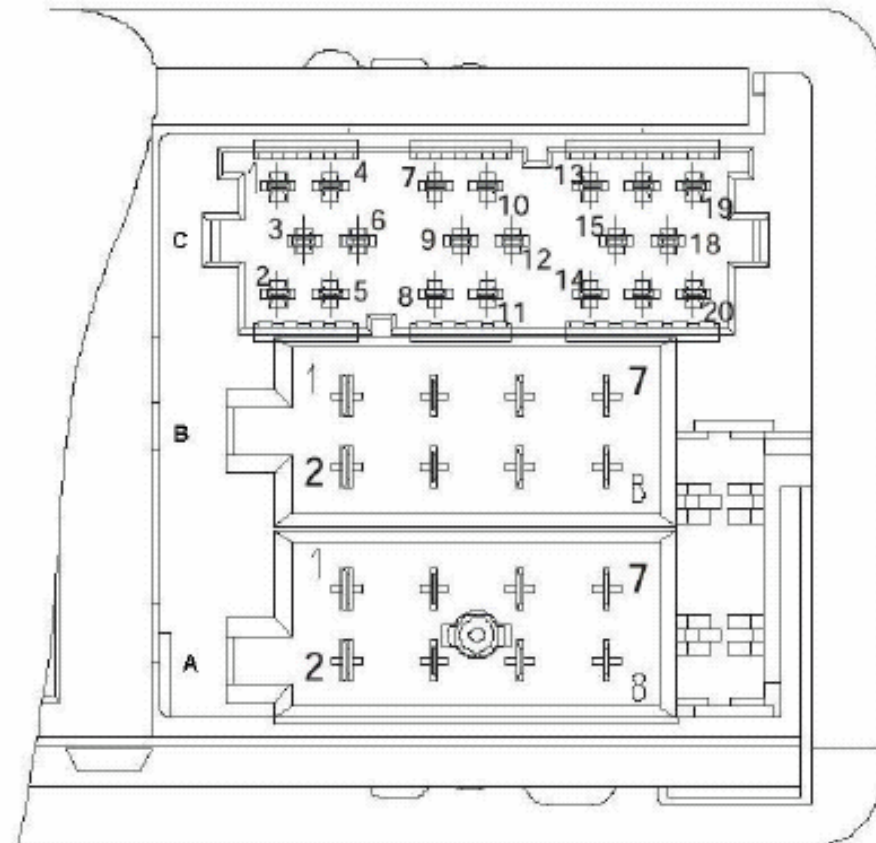

**DIN connector**



## CODE Radio delete (fleet orders only!)

Fleet orders only!

For cost and practical reason we do not recommend this option if a radio has to be retrofitted.

Radios are not easily retrofitted.

The radio slot gets a black cover.

No radio mounting provisions

No radio

No loudspeakers

No radio/speaker wiring

No roof antenna

Roof plug





## Antenna relocation

For relocating the roof antenna:

Antenna hole plug: A 906 820 01 12

The plug is black and will be screwed on.

An extension cable for the antenna wiring (local supply) can be used to relocate antenna.

Antenna has to be properly grounded.

