

PRE-ALIGNMENT INSPECTION

Before starting wheel alignment, the following inspection and necessary corrections must be completed. Refer to Suspension and Steering System Diagnosis Chart below for additional information.

1. Inspect tires for size, air pressure and tread wear.
2. Inspect front wheel bearings for wear.
3. Inspect front wheels for excessive radial or lateral runout and balance.
4. Inspect ball studs, linkage pivot points and steering gear for looseness, roughness or binding.
5. Inspect suspension components for wear and noise.
6. Road test the vehicle.

SUSPENSION AND STEERING SYSTEM DIAGNOSIS CONDITION	POSSIBLE CAUSES	CORRECTION
FRONT END NOISE	1. Loose or worn wheel bearing.	1. Replace knuckle.
	2. Loose or worn steering or suspension components.	2. Tighten or replace components as necessary.
	3. Loose or worn steering or suspension components.	3. Tighten or replace components as necessary.
EXCESSIVE PLAY IN STEERING	1. Loose or worn wheel bearing.	1. Replace knuckle.
	2. Loose or worn steering or suspension components.	2. Tighten or replace components as necessary.
	3. Loose or worn steering gear.	3. Replace steering gear.
FRONT WHEELS SHIMMY	1. Loose or worn wheel bearing.	1. Replace knuckle.
	2. Loose or worn steering or suspension components.	2. Tighten or replace components as necessary.
	3. Tires worn or out of balance.	3. Replace or balance tires.
	4. Alignment.	4. Align vehicle to specifications.
VEHICLE INSTABILITY	1. Loose or worn wheel bearing.	1. Replace knuckle.

	2. Loose or worn steering or suspension components.	2. Tighten or replace components as necessary.	
	3. Tire pressure.	3. Adjust tire pressure.	
	4. Alignment.	4. Align vehicle to specifications.	
EXCESSIVE STEERING EFFORT	1. Loose or worn steering gear.	1. Replace steering gear.	
	2. Column coupler binding.	2. Replace coupler.	
	3. Tire pressure.	3. Adjust tire pressure.	
	4. Alignment.	4. Align vehicle to specifications.	
VEHICLE PULLS TO ONE SIDE	1. Tire pressure.	1. Adjust tire pressure.	
	2. Tire.	2. Criss-Cross Front Tires.	
	3. Alignment.	3. Align vehicle to specifications.	
	4. Loose or worn steering or suspension components.	4. Tighten or replace components as necessary.	
	5. Radial tire lead.	5. Rotate or replace tire as necessary.	
	6. Brake pull.	6. Repair brake as necessary.	
	7. Weak or broken spring.	7. Replace spring.	

WHEEL ALIGNMENT, CURB HEIGHT, AND TORQUE SPECIFICATIONS

NOTE: Before each alignment check the front and rear curb heights of the vehicle. Verify that it is between minimum and maximum values given.

FRONT 2500 Series & 3500 Series WITHOUT REINFORCED FRONT AXLE	
DESCRIPTION	
2500 SERIES & 3500 SERIES WITHOUT reinforced front axle	
Toe-In	0.2° (±0.1°)
See front Curb Height Chart for proper specification per vehicle	
Camber	1.0° (±0.3°)
See front Curb Height Chart for proper specification per vehicle	
Caster	See Curb Height Chart for proper Caster specification per vehicle

FRONT 3500 series WITH REINFORCED FRONT AXLE	
DESCRIPTION	
3500 SERIES WITH reinforced front axle	
Toe-In	0.25° (±0.1°)
See front Curb Height Chart for proper specification per vehicle	
Camber	1.3° (±0.3°)

See front Curb Height Chart for proper specification per vehicle	
Caster	See Curb Height Chart for proper Caster specification per vehicle

FRONT AND REAR CURB HEIGHT SPECIFICATIONS

NOTE: Before each alignment check, measure the distance between the wheel center (2) and wheel well housing (1) on either side of the vehicle. Verify that it is between minimum and maximum values given. (This is the requirement for toe-in, camber and caster). Adjusting the rear curb height is not necessary when measuring it and choosing a spec from the table accordingly.

To check front curb height measure the distance between the wheel center (2) and the wheel well housing (1) which should be between the given specifications.

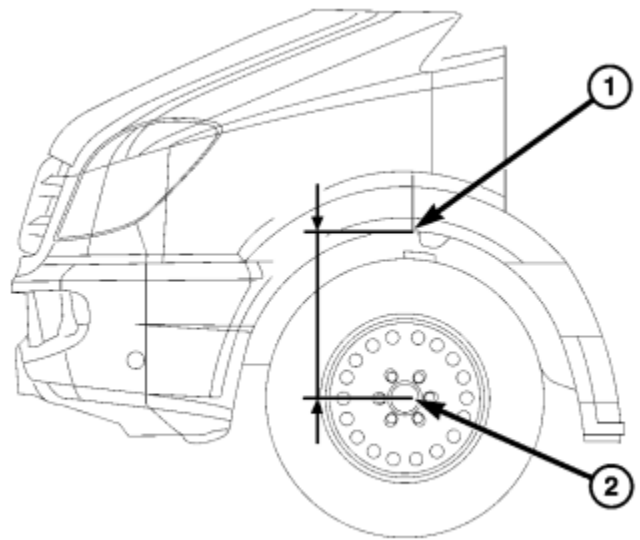

81c4dfda

To check Rear curb height measure the distance between the rear shock upper bolt (1) head to the lower bolt head (2).

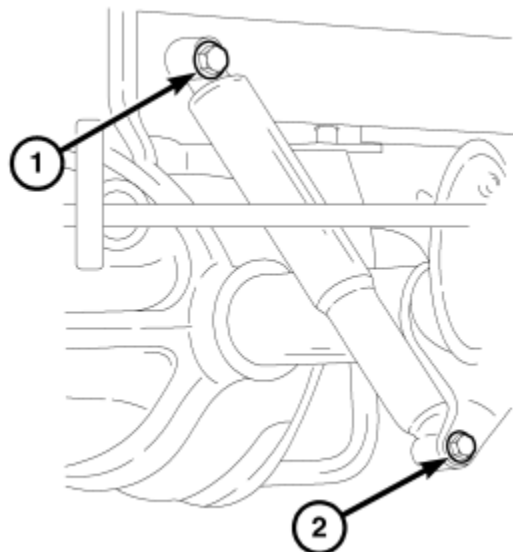

81dbd41c

2500 SERIES & 3500 SERIES without reinforced axle

DESCRIPTION

2500 SERIES & 3500 SERIES without reinforced axle. Mid Wheel Base Vehicle (3665 mm (144 in.))

FRONT CURB HEIGHT	REAR CURB HEIGHT	CASTER
467 mm (18.4 in.) Minimum	509 mm (20 in.)	2.6° (±0.5°)
502 mm (19.8 in.) Maximum	501 mm (19.7 in.)	2.8° (±0.5°)
	492 mm (19.3 in.)	2.9° (±0.5°)
	484 mm (19 in.)	3.1° (±0.5°)
	476 mm (18.7 in.)	3.2° (±0.5°)
	467 mm (18.3 in.)	3.4° (±0.5°)
	460 mm (18.1 in.)	3.6° (±0.5°)
	451 mm (17.7 in.)	3.7° (±0.5°)
	442 mm (17.4 in.)	3.9° (±0.5°)
	434 mm (17 in.)	4.0° (±0.5°)
	426 mm (16.7 in.)	4.2° (±0.5°)
	417 mm (16.4 in.)	4.3° (±0.5°)
	409 mm (16.1 in.)	4.5° (±0.5°)
	400 mm (15.7 in.)	4.7° (±0.5°)
392 mm (15.4 in.)	4.8° (±0.5°)	

3500 SERIES with reinforced axle

DESCRIPTION		
3500 SERIES with reinforced axle. Mid Wheel Base Vehicle (3665 mm (144 in.))		
FRONT CURB HEIGHT	REAR CURB HEIGHT	CASTER
497 mm (19.6 in.) Minimum	509 mm (20 in.)	2.7° (±0.5°)
513 mm (20.2 in.) Maximum	501 mm (19.7 in.)	2.9° (±0.5°)
	492 mm (19.3 in.)	3.0° (±0.5°)
	484 mm (19 in.)	3.2° (±0.5°)
	476 mm (18.7 in.)	3.3° (±0.5°)
	467 mm (18.3 in.)	3.5° (±0.5°)
	460 mm (18.1 in.)	3.7° (±0.5°)
	451 mm (17.7 in.)	3.8° (±0.5°)
	442 mm (17.4 in.)	4.0° (±0.5°)
	434 mm (17 in.)	4.1° (±0.5°)
	426 mm (16.7 in.)	4.3° (±0.5°)
	417 mm (16.4 in.)	4.4° (±0.5°)
	409 mm (16.1 in.)	4.6° (±0.5°)
	400 mm (15.7 in.)	4.7° (±0.5°)
	392 mm (15.4 in.)	4.9° (±0.5°)

2500 SERIES & 3500 SERIES without reinforced axle
DESCRIPTION

2500 SERIES & 3500 SERIES without reinforced axle. Long Wheel Base Vehicle (4325 mm (170 in.))

FRONT CURB HEIGHT	REAR CURB HEIGHT	CASTER
467 mm (18.4 in.) Minimum	509 mm (20 in.)	2.9° (±0.5°)
502 mm (19.8 in.) Maximum	501 mm (19.7 in.)	3.1° (±0.5°)
	492 mm (19.3 in.)	3.2° (±0.5°)
	484 mm (19 in.)	3.3° (±0.5°)
	476 mm (18.7 in.)	3.5° (±0.5°)
	467 mm (18.3 in.)	3.6° (±0.5°)
	460 mm (18.1 in.)	3.7° (±0.5°)
	451 mm (17.7 in.)	3.9° (±0.5°)
	442 mm (17.4 in.)	4.0° (±0.5°)
	434 mm (17 in.)	4.1° (±0.5°)
	426 mm (16.7 in.)	4.3° (±0.5°)
	417 mm (16.4 in.)	4.4° (±0.5°)
	409 mm (16.1 in.)	4.5° (±0.5°)
	400 mm (15.7 in.)	4.7° (±0.5°)
392 mm (15.4 in.)	4.8° (±0.5°)	

3500 SERIES with reinforced axle

DESCRIPTION

3500 SERIES with reinforced axle. Long Wheel Base Vehicle (4325 mm (170 in.))

FRONT CURB HEIGHT	REAR CURB HEIGHT	CASTER
-------------------	------------------	--------

497 mm (19.6 in.) Minimum	509 mm (20 in.)	3.0° (±0.5°)
513 mm (20.2 in.) Maximum	501 mm (19.7 in.)	3.1° (±0.5°)
	492 mm (19.3 in.)	3.3° (±0.5°)
	484 mm (19 in.)	3.4° (±0.5°)
	476 mm (18.7 in.)	3.5° (±0.5°)
	467 mm (18.3 in.)	3.7° (±0.5°)
	460 mm (18.1 in.)	3.8° (±0.5°)
	451 mm (17.7 in.)	3.9° (±0.5°)
	442 mm (17.4 in.)	4.1° (±0.5°)
	434 mm (17 in.)	4.2° (±0.5°)
	426 mm (16.7 in.)	4.3° (±0.5°)
	417 mm (16.4 in.)	4.5° (±0.5°)
	409 mm (16.1 in.)	4.6° (±0.5°)
	400 mm (15.7 in.)	4.7° (±0.5°)
	392 mm (15.4 in.)	4.9° (±0.5°)

TORQUE			
DESCRIPTION	N·m	Ft. Lbs.	In. Lbs.
Outer Tie Rod End Jam Nut	50	37	–