



Body Builder electrical Connectors (EK1)

Sprinter Engineering & Compliance

01-01-2010





Disclaimer

The specifications, descriptions, information, and recommendations contained in this bulletin are believed to be accurate as of Jan 1st, 2010.

Sprinter Engineering & Compliance reserves the right to modify or append this document without prior notification.

This bulletin is not intended as a work instruction, but as an aid for Body Builders to provide technical information necessary to retrofit or modify Mercedes-Benz Sprinters & Freightliner Sprinters (906).

Prior to making any modification to or installing any equipment in or on a Mercedes-Benz Sprinter & Freightliner Sprinter, please check with Sprinter Engineering & Compliance for additional and updated information, and read the Sprinter Body Builder Information Book Model Series 906.

www.sprinter-engineeringcompliance.com

Sprinter Engineering & Compliance Support Team Contacts:

Walther F Bloch
Manager
843-695-5053

Walther.bloch@daimler.com

Andreas Brockmann
Support Engineer
843-695-5052

andreas.j.brockmann@daimler.com

Jochen Hornikel
Test Engineer
843-695-5064

jochen.hornikel@daimler.com

Body Builder electrical connector inside driver seat base X145/1

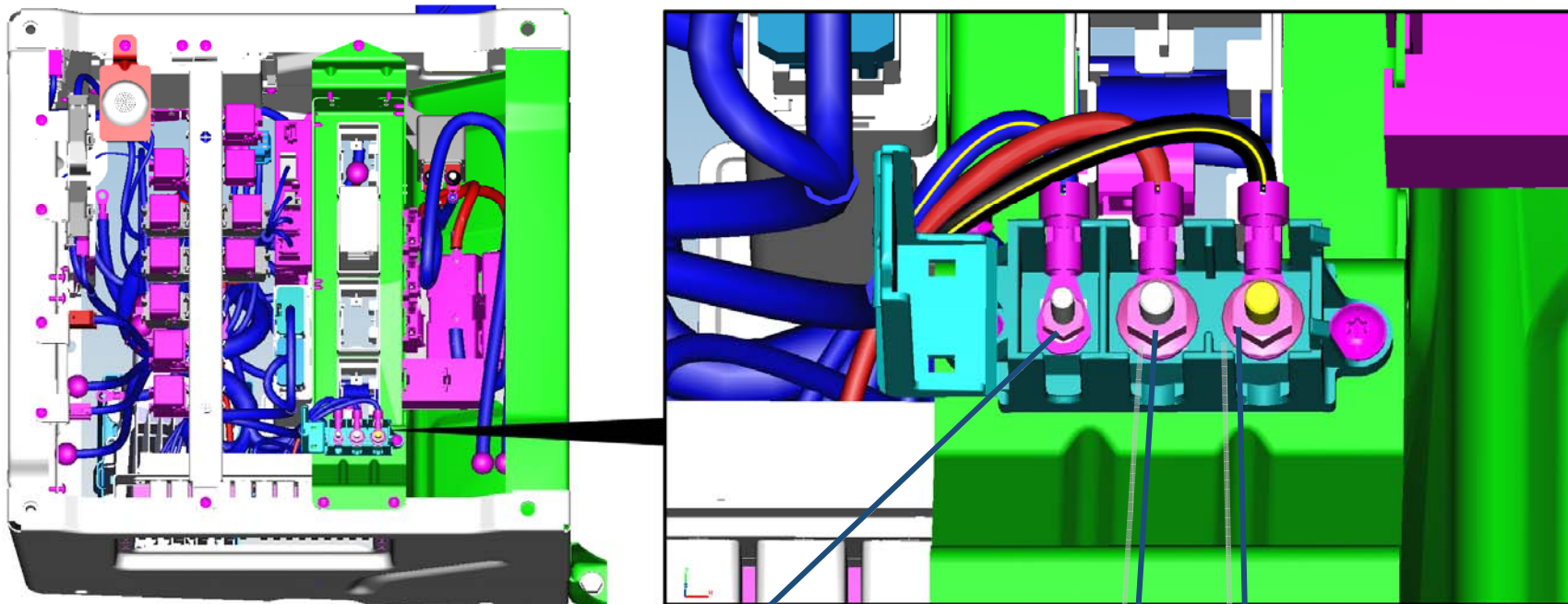

X145/1 Terminal 1 (D+)
Power with engine running
Wire color: blue/yellow
12 V/10 A (120 W)

X145/1 Terminal 2 (30)
Battery direct power
Wire color: red/gray
12 V/25 A (300 W)

X145/1 Terminal 3 (15)
Ignition power
Color: black/yellow
12 V/15 A (180 W)

Body Builder electrical connector inside driver seat base X145/1

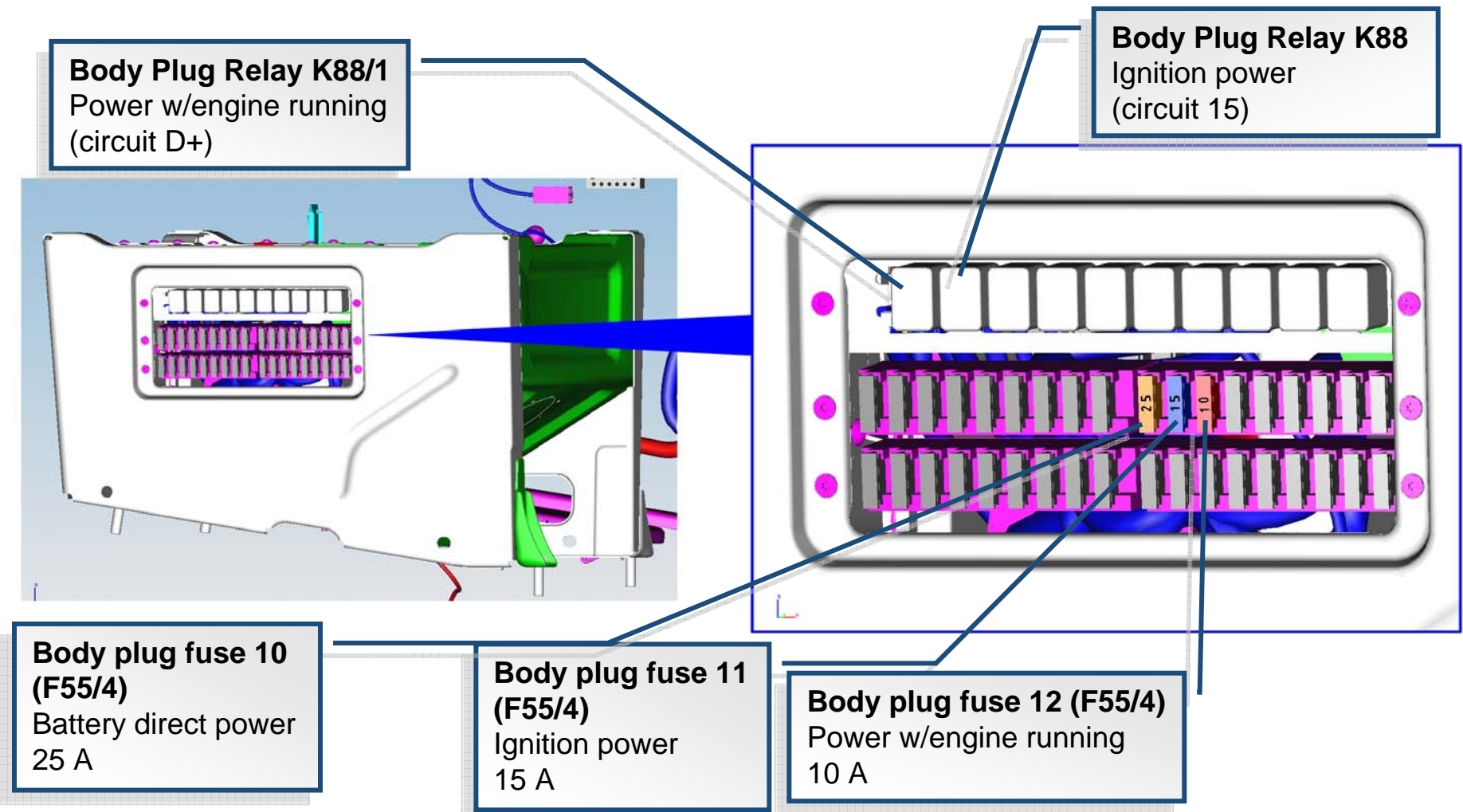

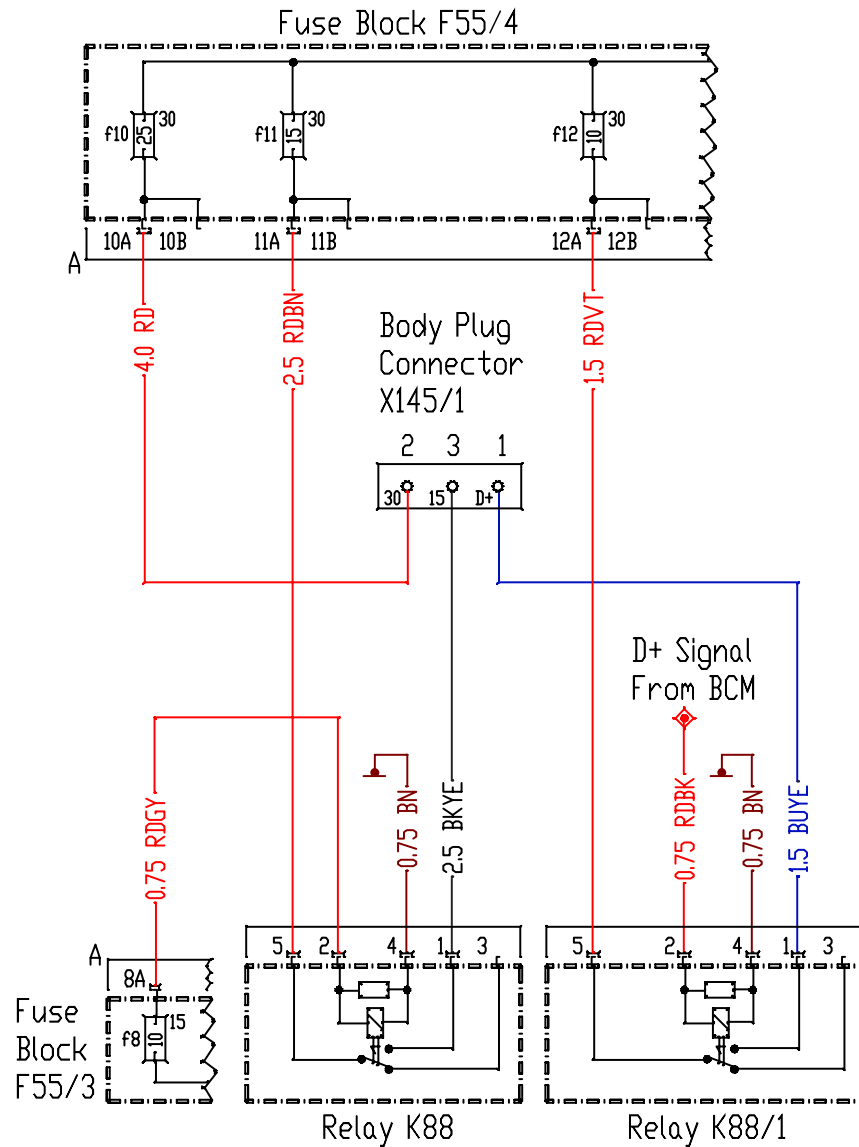

When installing electrical aftermarket equipment with an AMP draw of more than 25A it is necessary to use the optional aux battery 12V/100Ah (CODE E28)

See Aux Battery retrofitting guidelines.